

**SMD05 (0805)**  
**NTC SMD Thermistor**

**FEATURE**

- ◆ Small size, Low capacitance at 40 MHz (below 3 pF)
- ◆ Corresponding to high B value.
- ◆ Glass coated perform for long term reliability.
- ◆ Strong against electrostatic.
- ◆ Excellent in cost-performance.
- ◆ High accuracy and high environmental resistance are provided due to original manufacturing method.
- ◆ All Pb-free product [Pd and Cd are not contained in product]



**APPLICATIONS**

- ◆ Mobile communication related equipment. (TCXO, RF circuit, LCD panel, Battery pack).
- ◆ Computer related equipment.
- ◆ Temperature detection for CPU and memory equipment.
- ◆ Temperature compensation for contrast of LCD.
- ◆ Optical communication equipment.

**DESCRIPTION:**

- ◆ NTC thermistor is Negative Temperature Coefficient of Thermistor resistor.
- ◆ A thermistor is a thermally sensitive resistor whose primary function is to exhibit a change in electrical resistance with a change in body temperature.
- ◆ NTC thermistor is one in which the zero-power resistance decreases with an increase in temperature.

**ORDERING PROCEDURE:**

Example: SMD05103J3435HT

Type	Chip Size	Resistance	Tolerance	B-constant	B-tolerance	Package
SMD02	1005(0402)	101=100Ω	K = ±10%	3150~4100	K = ±10%	T = Reel
SMD03	1608(0603)	102=1KΩ	J = ±5%		J = ±5%	
SMD05	2012(0805)	103=10KΩ	H = ±3%		H = ±3%	
SMD06	3216(1206)	104=100KΩ	G = ±2%		G = ±2%	
			F = ±1%		F = ±1%	

**DIMENSION:**

Type	Chip Size	L (mm)	W (mm)	T (mm)	C (mm)
SMD02	1005(0402)	1.00±0.05	0.50±0.05	0.50±0.05	0.25±0.10
SMD03	1608(0603)	1.60±0.10	0.80±0.10	0.95±0.10	0.40±0.20
SMD05	2012(0805)	2.00±0.20	1.25±0.20	1.20±0.20	0.50±0.20
SMD06	3216(1206)	1.00±0.05	1.60±0.20	1.40±0.30	0.25±0.60

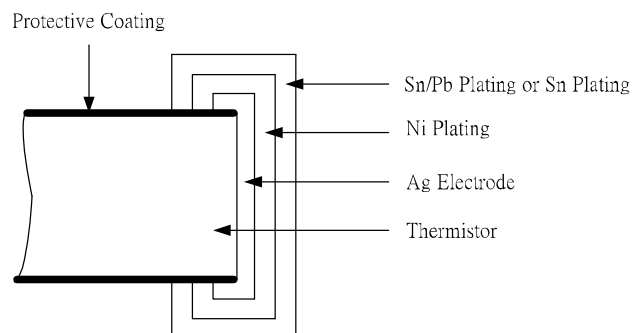
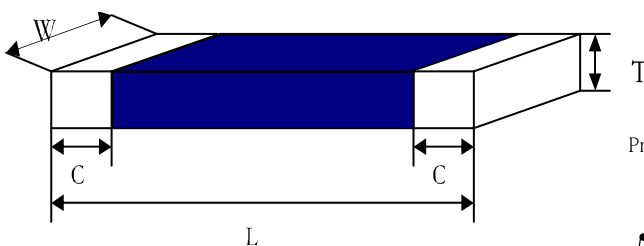

品質承諾標誌  
Quality Commitment

**2012 (0805) Size**

Part Number (SMD)	Resistance(25°C) (Ω)	B-constant (25-85°C) (k)	Maximum Power Rating (25°C) (mW)	Thermal Dissipation Constant (mW/°C)	Operating Temp. Range (°C)
05220□3150□	22	3150	400	4	-40 ~ 125
05300□3150□	30	3150			
05680□3150□	47	3150			
05101□3150□	68	3150			
05101□2800□	100	2800			
05101□3250□	100	3250			
05221□3250□	220	3250			
05102□3250□	1K	4100			
05202□3200□	2K	3200			
05202□4100□	2K	4100			
05222□3200□	2.2K	3200			
05472□3435□	4.7K	3435			
05472□3660□	4.7K	3660			
05472□4100□	4.7K	4100			
05502□3435□	5K	3435			
05103□3435□	10K	3435			
05103□3550□	10K	3550			
05103□3970□	10K	3970			
05103□4100□	10K	4100			
05123□3500□	12k	3500			
05123□3970□	12K	3970			
05153□3630□	15K	3630			
05223□3900□	22K	3900			
05223□4055□	22K	4055			
05233□3900□	23K	3900			
05303□3900□	30K	3900			
05333□4055□	33K	4055			
			400	4	-40 ~ 125



品質承諾標誌  
Quality Commitment

## 2012 (0805) Size

Part Number (SMD)	Resistance(25°C) (Ω)	B-constant (25-85°C) (k)	Maximum Power Rating (25°C) (mW)	Thermal Dissipation Constant (mW/°C)	Operating Temp. Range (°C)
□05473□4100□	47K	4100	400	4	-40 ~ 125
□05503□4000□	50K	4000			
□05563□4000□	56K	4000			
□05683□3950□	68K	3950			
□05104□4000□	100.0	4000			
□05104□4100□	100K	4100			
□05154□3800□	150K	3800			
□05154□4055□	150K	4055			
□05204□3950□	200K	3950			
□05224□4055□	220K	4055			
□05334□4100□	330K	4100			

※ Please inquire to our sales for other spec

Remark : 1. Maximum Power Rating = Thermal Dissipation Constant × (125°C - 25°C)

## REFLOW SOLDERING PROFILE

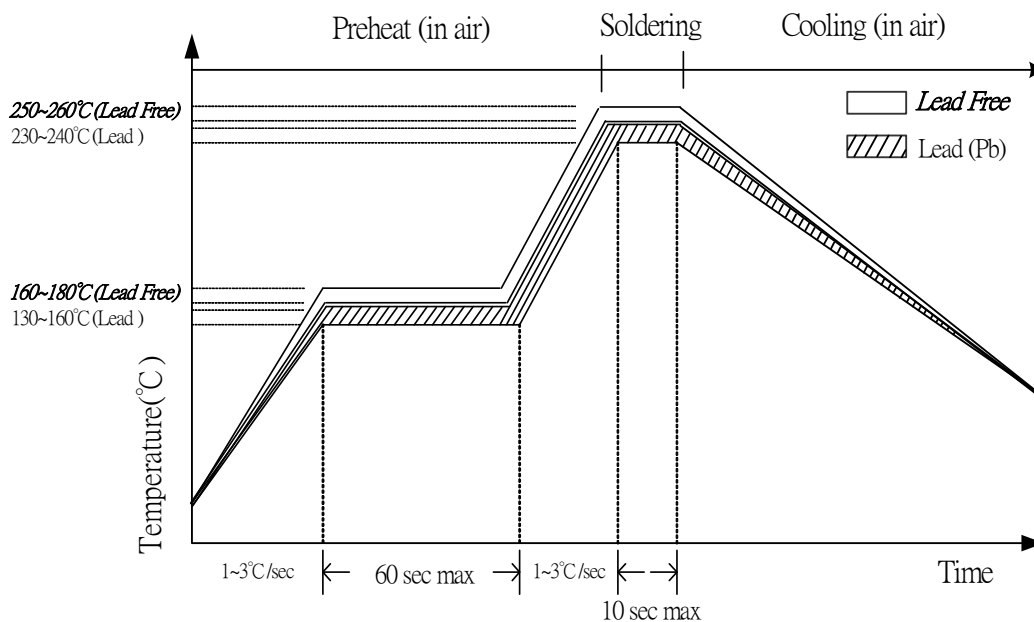

品質承諾標誌  
Quality Commitment

## BASIC CHARACTERISTICS

### 1. Zero-power Resistance of Thermistor

$$R = R_0 \exp B (1/T - 1/T_0) \dots\dots\dots(1)$$

R : Resistance in ambient temperature T (K)  
(K : absolute temperature)

R<sub>0</sub> : Resistance in ambient temperature T<sub>0</sub> (K)

B : B-constant of Thermistor

### 2. B-Constant

As (1) formula

$$B = \ln (R/R_0) / (1/T - 1/T_0) \dots\dots\dots(2)$$

### 3. Thermal Dissipation Constant

When spend electric power P (mW) in ambient temperature T<sub>1</sub>, if Thermistor temperature rises T<sub>2</sub>, there is a formula as follows

$$P = C (T_2 - T_1) \dots\dots\dots(3)$$

C : Thermal dissipation constant (mW/°C)

Thermal dissipation constant change by dimensions, measure, measured condition etc.

### 4. Thermal Time Constant

Period in which Thermistor temperature will change 63.2% of its temperature difference from ambient temperature T<sub>0</sub> (°C) to T<sub>1</sub> (°C).

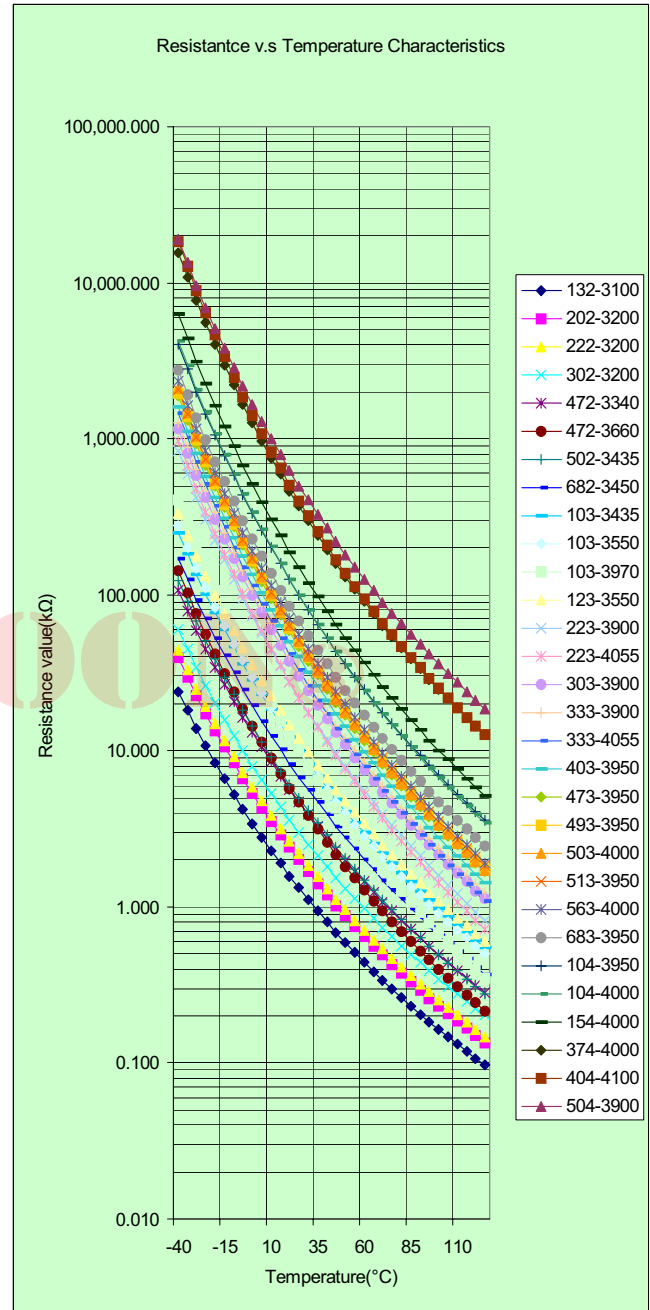
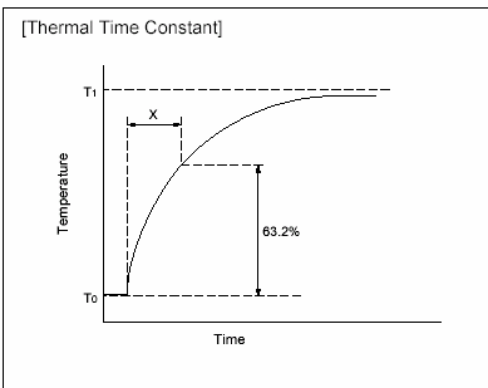

品質承諾標誌  
Quality Commitment

## RELIABILITY TEST

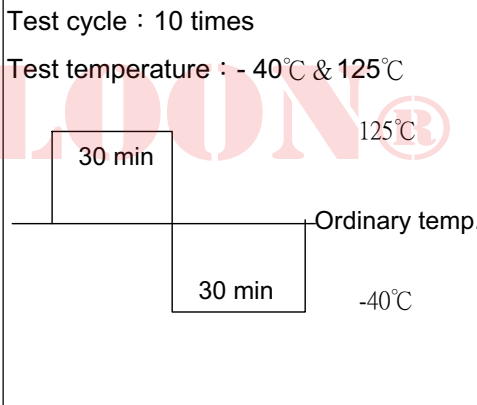
Test Item		Standard	Test Method	$\Delta R_{25} / R_{25}$
Environmental test	Life	MIL-STD-202F Method 108A	Test temperature : 70°C Test duration : 1000 hrs Load power : 1206 – 6.5 mW , 0805 – 5.0 mW , 0603 – 4.5 mW , 0402 – 3.5 mW ◦	MAX. ± 3 %
	Humidity	MIL-STD-202F Method 103B	Test temperature : 40°C Test humidity : 95% Test duration : 1000 hrs Load power : 1206 – 6.5 mW , 0805 – 5.0 mW , 0603 – 4.5 mW , 0402 – 3.5 mW ◦	MAX. ± 3 %
	Thermal shock	MIL-STD-202F Method 107G	Test cycle : 10 times Test temperature : - 40°C & 125°C  Ordinary temp.	MAX. ± 3 %
	Storage in dry heat	IEC 68-2-2	Test temperature : 125°C Test duration : 1000 hrs	MAX. ± 3 %
Mechanical Performance test	Solderability	MIL-STD-202F Method 208 H	Soldering temperature : 235°C Duration of immersion : 2 seconds	95 % min. coverage
	Resistance to soldering heat	MIL-R-55342D PARA 4.7.7	Soldering temperature : 260°C Duration of immersion : 10 seconds	MAX. ± 3 %

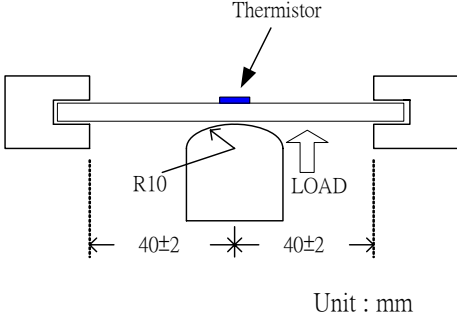
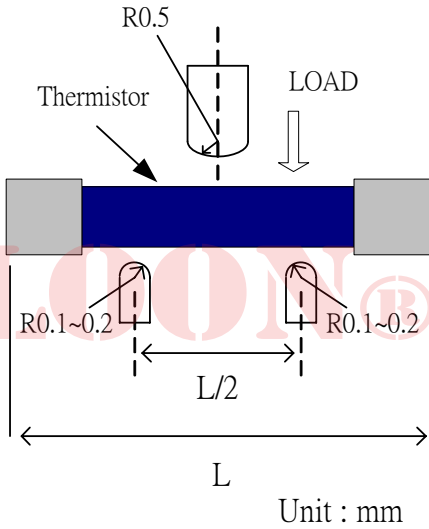
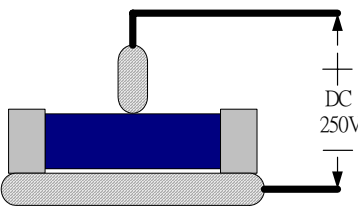
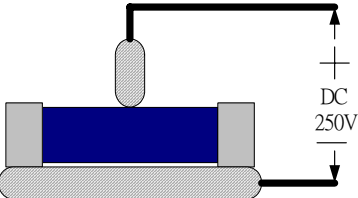

Mechanical Performance test	Bending strength	JIS C 5202 6.1.4	<p>Pressurizing rod at a rate of 1mm/sec Maintenance time : 5 sec Bending distance : 1 mm (min.)</p>  <p>Unit : mm</p>	Visual : No mechanical damage
	Resistance to flexure of substrate	JIS C 5202 6.2.1	<p>Pressurizing force shall be 3kg</p>  <p>Unit : mm</p>	MIN. 3Kg
Electrical Performance test	Insulation resistance	MIL-STD-202F Method 302	<p>DC 250V For 10 seconds</p> 	Over 1000MΩ
	Dielectric withstand voltage	MIL-STD-202F Method 301	<p>DC 250V For 10 seconds</p> 	NOT Short



## MOUNTING POSITION

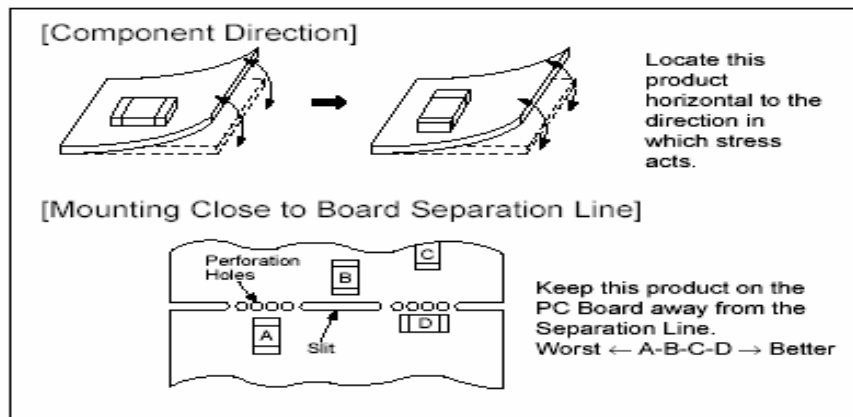

Choose a mounting position that minimize the stress imposed on the chip during flexing or bending of the board

## TAPE DIMENSIONS

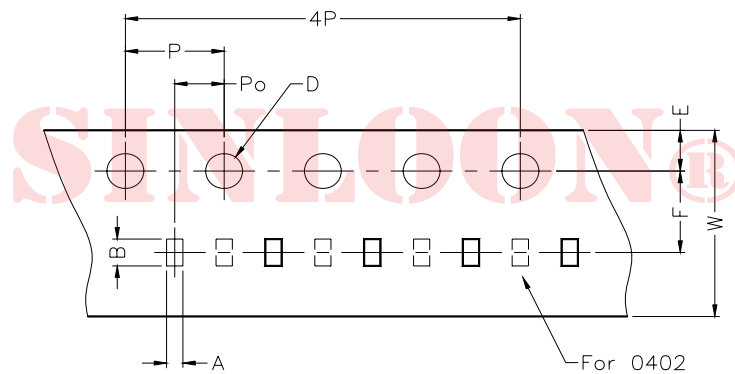

Dimension	1206	0805	0603	0402
A	2.00 ± 0.05	1.50 ± 0.05	1.08 ± 0.05	0.66 ± 0.03
B	3.57 ± 0.05	2.30 ± 0.05	1.85 ± 0.05	1.15 ± 0.03
W	8.00 ± 0.02	8.00 ± 0.05	8.00 ± 0.05	8.00 ± 0.05
D	1.55 ± 0.05	1.50 ± 0.10	1.50 ± 0.10	1.50 ± 0.10
E	1.75 ± 0.10	1.75 ± 0.05	1.75 ± 0.05	1.75 ± 0.05
F	3.50 ± 0.05	3.50 ± 0.05	3.50 ± 0.05	3.50 ± 0.05
P	4.00 ± 0.10	4.00 ± 0.05	4.00 ± 0.05	4.00 ± 0.05
P <sub>o</sub>	2.00 ± 0.05	2.00 ± 0.05	2.00 ± 0.05	2.00 ± 0.05
4P	16.00 ± 0.05	16.00 ± 0.05	16.00 ± 0.05	16.00 ± 0.05



## REFLOW SOLDERING PROFILE

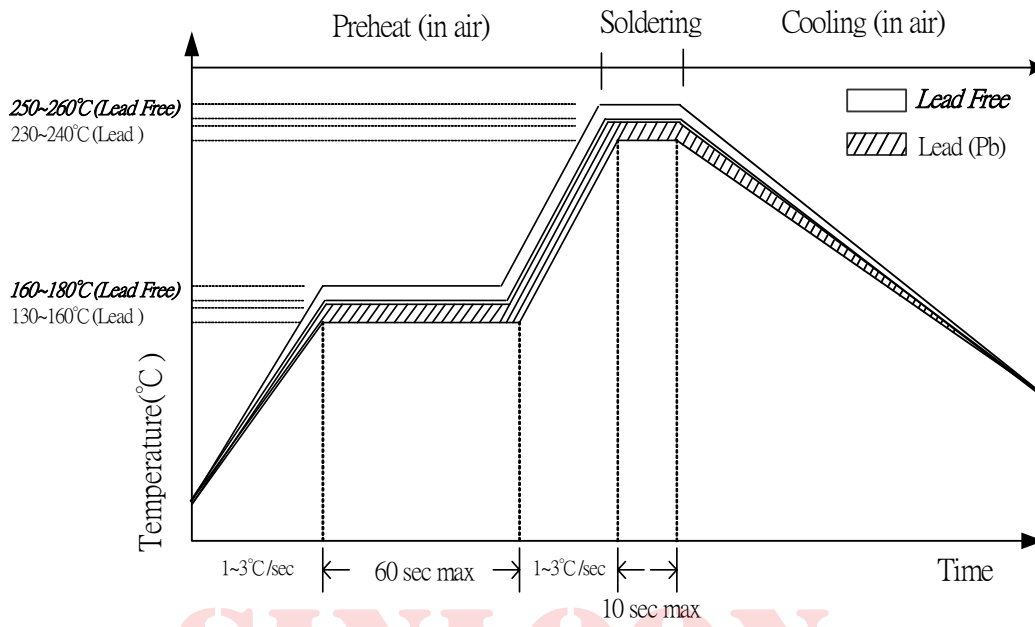

SINLOON®

## REEL DIMENSIONS

Unit : mm

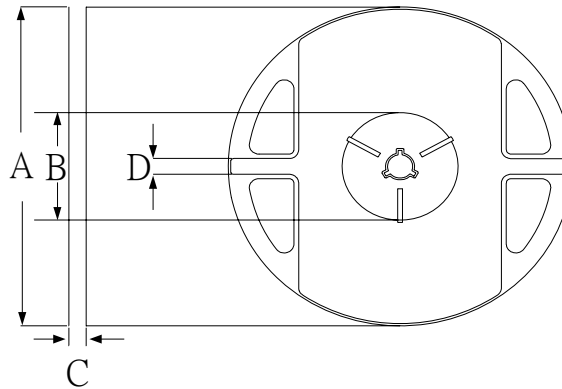

Unit : mm

ITEM	A	B	C	D
Dimension	178.0 ± 1.0	60.0 ± 1.0	9.0 ± 0.1	13.0 ± 0.1



品質承諾標誌  
Quality Commitment