

SINLOON®

肖特基二極管
Case: TO-3P

S30D30C - S30D60C (30V~100V)
30A Dual Schottky Barrier Rectifier

Feature

- ◆ Schottky Barrier Chip
- ◆ Guard Ring for Transient Protection
- ◆ Low Forward Voltage Drop
- ◆ Low Reverse Leakage Current
- ◆ High Surge Current Capability
- ◆ Plastic Material has UL Flammability Classification 94V-0

Figure

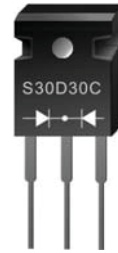

Mechanical Data

- ◆ Case: TO-3P, Moldes Plastic
- ◆ Terminals: Plated Leads Solderable per MIL-STD-750, Method 2026
- ◆ Polarity: See Diagram
- ◆ Weight: 5.6 grams (approx)
- ◆ Mounting Position: Any
- ◆ Mounting Torque: 11.5 cm·kg (10 in·lbs) max.
- ◆ Lead Free: For **RoHS** / Lead Free Version Add "-LF" Suffix to part Number.

Dimension

Case: TO-3P (mm)

Dim.	Min.	Max.
A	3.2	3.5
B	4.7	5.3
C	---	23.0
D	19	---
E	2.8	3.2
G	0.45	0.85
H	---	16.2
J	1.7	2.7
ΦK	3.15	3.7
L	---	4.5
M	5.25	5.65
N	1.1	1.4
P	---	2.5
R	11.7	12.7
S	5.0	6.0

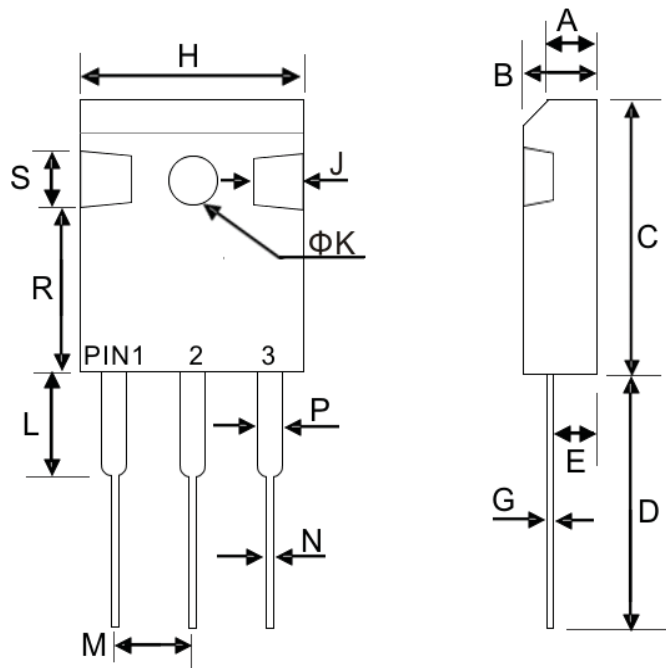

Marking Information

- S30DxxC = Device Number
- xx = See Page 2
- Polarity = As Marked Body

Electrical Symbol

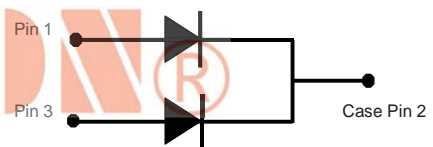
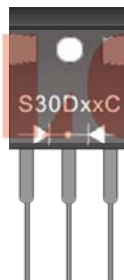

Maximum Ratings and Electrical Characteristics @T_A=25°C unless otherwise specified

Single Phase, half wave, 60Hz, resistive or inductive load For capacitive load, derate current by 20%.

Characteristics	Symbol	S30D								Unit
		30C	35C	40C	45C	50C	60C	80C	100C	
Peak Repetitive Reverse Voltage	V _{RRM}									
Working Peak Reverse Voltage	V _{RWM}	30	35	40	45	50	60	80	100	V
DC Blocking Voltage	V _R									
RMS Reverse Voltage	V _{R(RMS)}	21	25	28	32	35	42	56	70	V
Average Rectified Output Current @T _C =100°C	I _O	30.0			30.0			30.0		A
Non-Repetitive Peak Forward Surge Current 8.3ms Single half sine-wave superimposed on rated load (JEDEC Method)	I _{FSM}	275			275			275		A
Forward Voltage @I _F =10A	V _{FM}	0.55			0.65			0.85		V
Peak Reverse Current @T _A = 25°C	I _{RM}	1.0								mA
At Rated DC Blocking Vol. @T _A =100°C		60								
Typical Junction Capacitance (Note 1)	C _j	1100								pF
Typical Thermal Resistance Junction to Case (note 2)	R _{θJC}	1.4								°C/W
Operating and Storage Temperature Range	T _j , T _{STG}	-65 to +150								°C

Note 1: Measured at 1.0 MHz and applied reverse voltage of 4.0V D.C.

Note 2: Thermal resistance Junction to case mounted on heatsink.

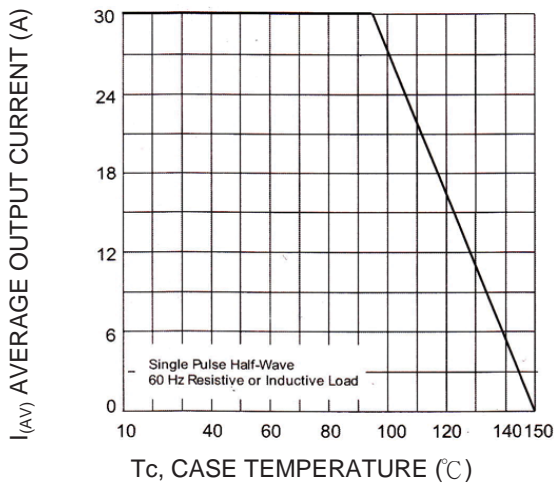

Fig-1 Forward and Current Derating Curve

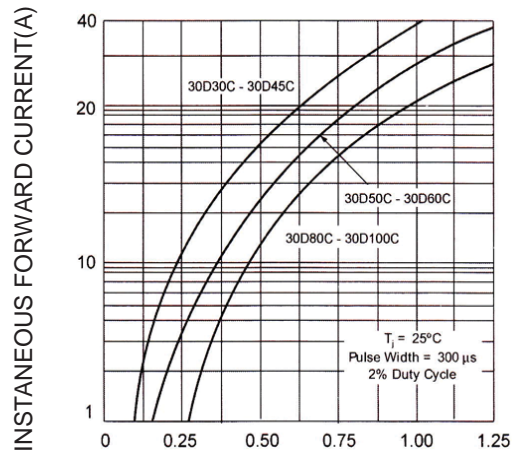

Fig-2 Typical Forward Voltage data per Element.

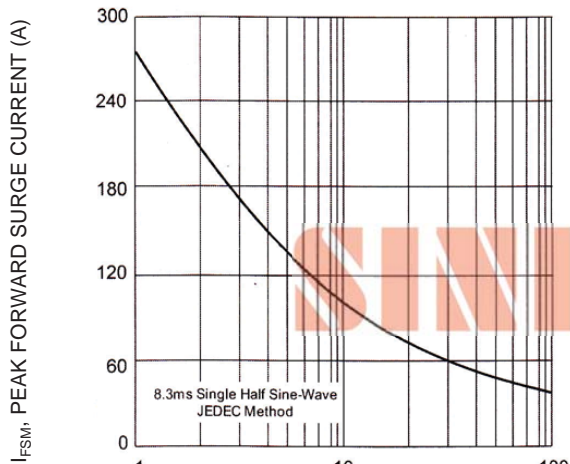

Fig-3 Max. Non-Repetitive Peak Forward Surge Current

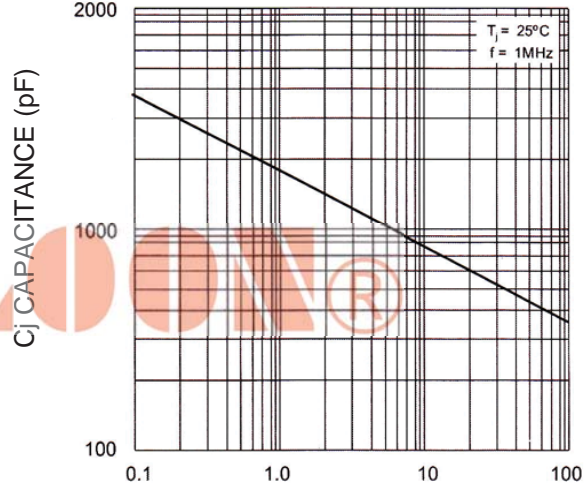

Fig-4 Typical Junction Capacitance per Element

SINLOON®

肖特基二極管
Case: TO-3P

S30D30C - S30D60C (30V~100V)
30A Dual Schottky Barrier Rectifier

Packaging Information

Tube Size LxWxH (mm)	Quantity (Pcs)	Inner Box Size LxWxH (mm)	Quantity (Pcs)	Carton Size LxWxH (mm)	Quantity (Pcs)	Gross Weight
505x46x6.5	30	520x145x95	1200	540x306x115	2400	18.0

Note: Anti-static tube, water clear color.

Anti-static tube: Quantity: 30 pcs

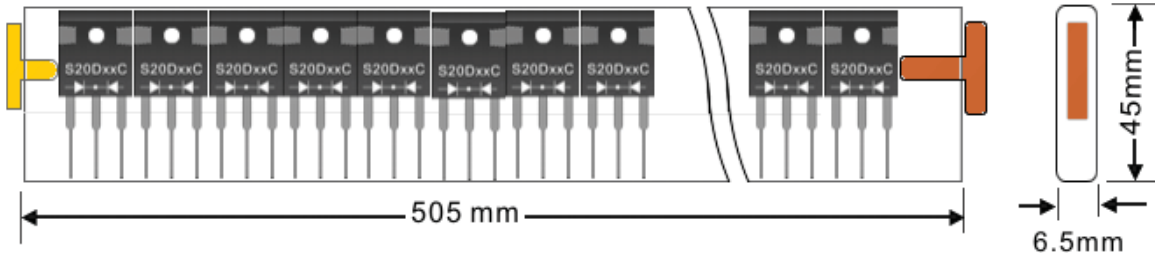

Inner Box : Quantity: 1200 pcs

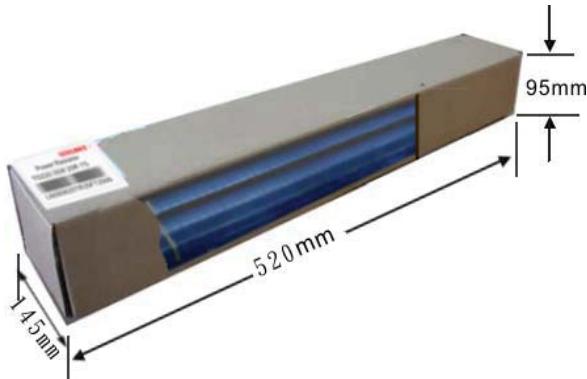

Carton Package: Quantity: 2400 pcs

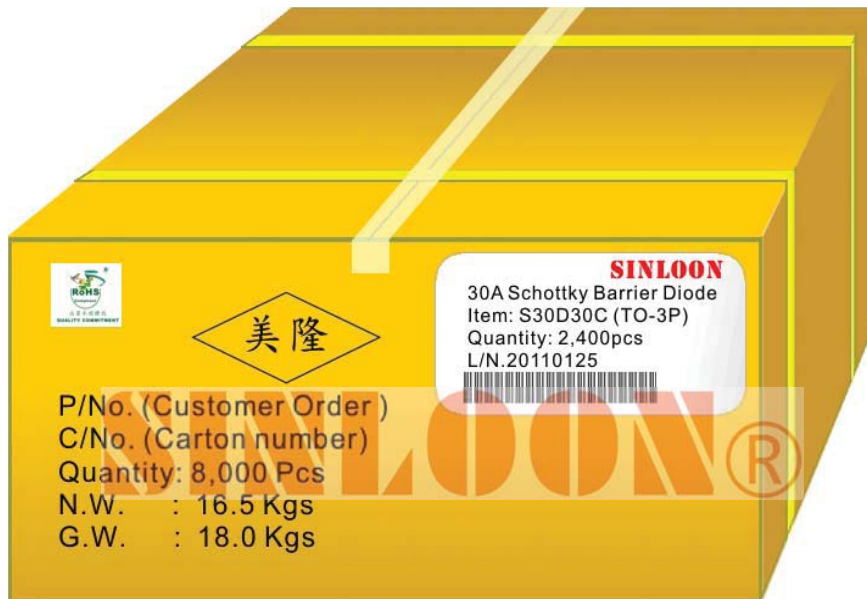

□ Package Mounting Guide

It is important that the packages are correctly mounted if full functionality is to be achieved. Mounting of the package to a heat sink must be done such that there is sufficient pressure from the mounting screws to insure good contact with the heat sink for efficient heat flow. Incorrect mounting may lead to both thermal and mechanical problems. Over tightening the mounting screws will cause the package to warp reducing the contact area with the heat sink and increasing the thermal resistance from the package case to the heat sink, resulting in higher operating die temperatures. Extreme over tightening of the mounting screws beyond the recommended torque force will cause severe physical stress resulting in cracked die and catastrophic IC failure. Though the reliability of the package is excellent, the use of inappropriate techniques or unsuitable tools during the mounting process can affect the long term reliability of the device and even damage it.

□ Recommended Screw Mount Arrangement

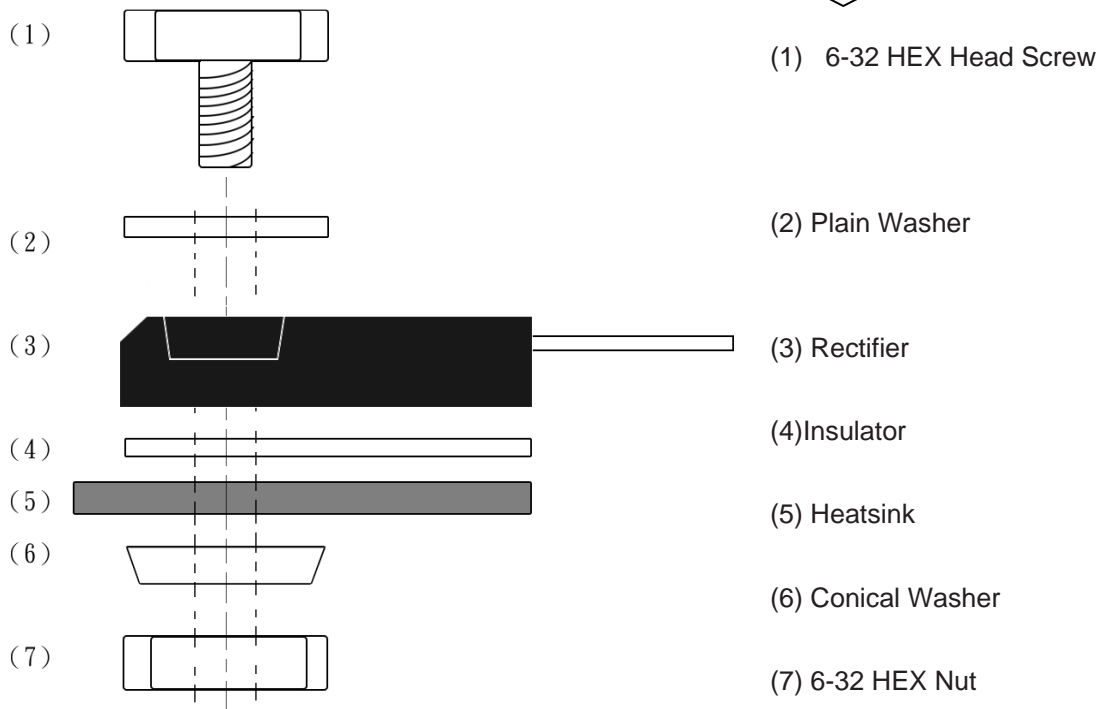

- ◆ Recommended isolated mounting when screw is at heat-sink potential 6-32 hardware is used.
- ◆ A conical washer should be used to apply proper force to the device.
- Screw should not be tightened with any type of air-forced torque or equipment that may cause high impact on device package.
- ◆ The interface should apply a layer of thermal grease or a highly conductive thermal pad for better heat dissipation.

※美隆公司產品規格及其特性參數的改變或更新恕不另行通知。

※Mayloon characteristic parameters of electronic product specification changes or updates without notice to improve。